

TELEOPERATION OF MOBILE ROBOTS

E. SLAWIŃSKI, V. MUT and J.F. POSTIGO

*Instituto de Automática (INAUT). Universidad Nacional de San Juan.
Av. Libertador San Martín 1109 (oeste). J5400ARL. San Juan, Argentina.
e-mail:{slawinski, vmut, jpostigo}@inaut.unsj.edu.ar*

Abstract— This paper proposes a stable control structure for bilateral teleoperation of mobile robots. The proposed control structure includes a time-delay compensation placed on both the local and remote sites of the teleoperation system. Teleoperation experiments through a simulated and real (using Internet) communication channel are presented to illustrate the performance and stability of the proposed control structure.

Keywords— asymptotic stability, mobile robots, teleoperation, time varying delay.

I. INTRODUCTION

Teleoperation systems have been developed to allow human operators to execute tasks in remote or hazardous environments, with a variety of applications ranging from space to underwater, nuclear plants, and so on (Sheridan, 1995). In general, the bilateral teleoperation systems of mobile robots are composed by a local site (where a human operator drives a hand-controller device); a remote site (where a mobile robot interacts with the physical world); and a communication channel that links both sites. The human operator generates velocity commands to the remote mobile robot, while the position of the mobile robot is back-fed to the human operator through the communication channel.

Perhaps, the most interesting case appears when there exists a distance between the local and remote sites of a teleoperation system. This generally introduces time varying delays adding distortion in the reference commands and feedback signals. The presence of time delay may induce instability or poor performance of a teleoperation system (Fiorini and Oboe, 1997; Richard, 2003). In general, in the design of teleoperation systems there is a trade-off between high transparency and sufficient stability margins (Lawrence, 1993). Main control strategies proposed for bilateral teleoperation of delayed systems are described in Anderson and Spong (1989), Niemeyer and Slotine (1991), Oboe and Fiorini (1998), Oboe (2003), Elhajj *et al.* (2003) and Chopra and Spong (2003). In general, the proposed control structures keep the passivity or stability at the expenses of reducing the system transparency (Arcara and Melchiorri, 2002).

This paper proposes a stable control structure for

bilateral teleoperation of mobile robots. The proposed control structure is based on combining the velocity command generated by the human operator in a delayed time instant, the received position information (which stimulates the operator) in such moment and the current position of the mobile robot to set the velocity reference of the mobile robot. The time proposed delay compensation is placed on the local and remote sites. Moreover, experiences of teleoperation of a mobile robot are shown to test the stability and performance of the designed teleoperation system.

The paper is organized as follows: Section II gives the notation used in this paper. In section III, some background material on delayed differential equations is introduced. Section IV presents the statement of the control problem. In Section V, a model of the human operator for motion control is presented. In Section VI, a stable control structure for bilateral teleoperation of mobile robots is proposed. In section VII, the stability and performance of the proposed control structure are analyzed through teleoperation experiments using a simulated and real (Internet) communication channel. Finally, the conclusions of this paper are given in Section VIII.

II. NOTATION

In this paper, the following notation is used: $h(t) \in \mathfrak{R}^+$ denotes the time delay. Here, $x(t) \in \mathfrak{R}^n$, x^T is the transpose of x , $\|x\|$ is the Euclidean norm of x , x_t (for a given time instant t) is the function defined by $x_t(\theta) = x(t+\theta)$ for $\theta \in [-h(t), 0]$, for example: $x_t(0) = x(t)$, $x_t(-h) = x(t-h)$; and the norm $\|x_t\|$ is defined by $\|x_t\| = \sup_{\theta \in [-h(t), 0]} \|x(\theta)\|$. $C_{n,h(t)}$ is the n -dimensional space of continuous functions on the interval $[t-h(t), t]$ at any time t , then the function $x_t \in C_{n,h(t)}$. On the other hand, given a non-linear differentiable function $\dot{x}(t) = g(x(t), x(t-h))$, the incremental gain of g is defined as $|g| = \inf \{ \gamma : |g(x_1, x_2) - g(y_1, y_2)| \leq \gamma [|x_1 - x_2| + |y_1 - y_2|] \}$ $\forall x_1, x_2, y_1, y_2 \in \mathfrak{R}^n$.

III. STABILITY OF DELAYED SYSTEMS

The robot teleoperation systems are represented by delayed differential equations. In this section, we show standard definitions and facts in the theory of delayed

functional differential equations (Krasovskii, 1963; Hale 1977; Kolmanovskii and Myshkis, 1999). In addition, we propose a stability condition for systems with time delay, which will be used in Section VI for the stability analysis of the proposed teleoperation system.

Let's consider the delayed functional differential equation given by,

$$\dot{x}(t) = f_1(t, x_t), \quad f_1(t, 0) = 0, \quad \forall t \geq t_0, \quad (1)$$

where $x \in \mathfrak{R}^n$, $x_t \in C_{n,h(t)}$, $t, t_0 \in \mathfrak{R}^+$, and $f_1: \mathfrak{R}^+ \times C_{n,h(t)} \rightarrow \mathfrak{R}^n$. It is assumed that there exists a solution $x(t; t_0, \psi_0)$ of (1) with initial data $[t_0, \psi_0]$, where $\psi_0 = x(t_0 + \theta)$ for $\theta \in [-h(t_0), 0]$ with $\|\psi_0\| < H \in \mathfrak{R}^+$, which depends continuously on the initial data. From now on, we will denote the solution norm by $|x(t; t_0, \psi_0)| = |x(t, 0)|$.

Definition 1. The solution $x_t = 0$ of (1) is said to be asymptotically stable if,

- a) For every $\varepsilon > 0$ and each $t_0 \geq 0$ there exists $\rho = \rho(\varepsilon, t_0)$ such that $\|\psi_0\| < \rho$ implies that $|x(t; t_0, \psi_0)| < \varepsilon$ for all $t_0 \geq 0$.
- b) For every $t_0 \geq 0$ there exists $\varepsilon_1 = \varepsilon_1(t_0)$ such that if $\|\psi_0\| < \varepsilon_1$, then $|x(t; t_0, \psi_0)| \rightarrow 0$ as $t \rightarrow \infty$.

If ρ and ε_1 are independent from the initial time t_0 , then the zero-solution is uniformly asymptotically stable.

Fact 1 (Krasovskii, 1963). Let's suppose that the function $f_1: \mathfrak{R}^+ \times C_{n,h(t)} \rightarrow \mathfrak{R}^n$ maps bounded sets of $C_{n,h(t)}$ in bounded sets of \mathfrak{R}^n , and that $u(\cdot), v(\cdot)$ and $w(\cdot)$ are scalar, continuous, positive and non-decreasing functions. If there exists a continuous functional $V: \mathfrak{R}^+ \times C_{n,h(t)} \rightarrow \mathfrak{R}^+$, and the following conditions hold:

$$u(|x_t(0)|) \leq V(t, x_t) \leq v(\|x_t\|) \quad (2)$$

$$\dot{V}(t, x_t) < -w(|x_t(0)|), \quad (3)$$

where $\dot{V}(t, x_t)$ is the time-derivative of $V(t, x_t)$ along the trajectories of (1); then the solution $x_t = 0$ is uniformly asymptotically stable.

Now, let us consider a non-linear system with time varying delay described by,

$$\dot{x}(t) = f_2(t, x(t)) + g(t, x(t), x(t-h)), \quad (4)$$

where $0 \leq h(t) \leq h_m$ and $\dot{h}(t) < \tau < 1$, with $h_m \in \mathfrak{R}^+$, $x \in \mathfrak{R}^n$, $t, t_0 \in \mathfrak{R}^+$, $f_2: \mathfrak{R}^+ \times \mathfrak{R}^n \rightarrow \mathfrak{R}^n$, and $g: \mathfrak{R}^+ \times \mathfrak{R}^n \times \mathfrak{R}^n \rightarrow \mathfrak{R}^n$. In addition, we assume that $f_2(t, 0) = 0$ and $g(t, 0, 0) = 0$, for $\forall t \geq t_0$.

Lemma 1. If a system represented by $\dot{x} = f_2(x)$ is exponentially stable, then there exist $\alpha, \lambda \in \mathfrak{R}^+$ such that $x^T f_2(x) \leq -\lambda x^T x$, where $|x| \leq \alpha |x(0)| e^{-\lambda t}$.

Proof. If the system $\dot{x} = f_2(x)$ is exponentially stable, then it satisfies that $|x| \leq \alpha |x(0)| e^{-\lambda t}$, and therefore:

$$x \leq \alpha |x(0)| e^{-\lambda t} I_1, \quad (5)$$

where $I_1 \in \mathfrak{R}^n$ with $I_1(i) = 1$ for $0 < i \leq n$. From (5), the evolution of \dot{x} verifies that,

$$\dot{x} \leq -\lambda \alpha |x(0)| e^{-\lambda t} I_1. \quad (6)$$

Using (5) and (6) on $-\lambda x^T x$, the following can be expressed:

$$-\lambda x^T x \geq -\lambda (\alpha |x(0)| e^{-\lambda t}) (\alpha |x(0)| e^{-\lambda t}) I_1^T I_1 \geq x^T \dot{x} = x^T f_2(x). \quad (7)$$

Inequality (7) proves the proposed Lemma. Δ

Theorem 1. Let us suppose that the subsystem $\dot{x} = f_2(x)$ of the system (4) is exponentially stable with rate λ , then the following condition ensures the asymptotic stability of the system (4):

$$-\lambda + |g| \left[\frac{2 - \frac{3}{2}\tau}{1 - \tau} \right] < 0, \quad (8)$$

where $\lambda, |g| \in \mathfrak{R}^+$ and $\dot{h}(t) < \tau < 1$. The norm $|g|$ is the incremental gain of the operator $g(\cdot)$.

Proof. A functional $V: \mathfrak{R}^+ \times C_{n,h(t)} \rightarrow \mathfrak{R}^+$ is proposed as follows,

$$V(t, x_t) = \frac{1}{2} x^T x + \frac{1}{2} \frac{|g|}{1 - \tau} \int_{t-h(t)}^t x^T(\theta) x(\theta) d\theta > 0. \quad (9)$$

where the proposed functional incorporates information of the delayed dynamics ($|g|$) that will help to reach a stability condition that will directly depend on the time-derivative of the varying-time delay and the non-delayed dynamics of the delayed system.

From (9) and considering that the delay $h(t)$ is bounded ($h(t) \leq h_m$) and that $x^T x = |x(0)|^2 \leq \|x\|^2$ (by using norm properties), then the proposed functional $V(t, x_t)$ verifies condition (2) –given by *Fact 1*–,

$$\frac{1}{2} |x(0)|^2 \leq V(t, x_t) \leq \frac{1}{2} \|x_t\|^2 + \frac{1}{2} \frac{|g|}{1 - \tau} \|x_t\|^2 h_m. \quad (10)$$

The time-derivative of $V(t, x_t)$ along the system trajectories (4) is,

$$\dot{V}(t, x_t) \leq x^T f_2(x) + x^T g(x, x(t-h)) + \frac{1}{2} \frac{|g|}{1 - \tau} x^T x - \frac{1}{2} \frac{|g|(1-h)}{1 - \tau} x_t(-h)^T x_t(-h). \quad (11)$$

Now, the following inequalities are attained using norm properties,

$$\begin{aligned} x^T g(x, x(t-h)) &\leq |x| |g| (|x| + |x(t-h)|) \leq |g| |x|^2 + |g| |x| |x(t-h)| \\ &\leq |g| |x|^2 + \frac{|g|}{2} |x|^2 + \frac{|g|}{2} |x(t-h)|^2 \leq \frac{3}{2} |g| |x|^2 + \frac{1}{2} |g| |x(t-h)|^2. \end{aligned} \quad (12)$$

Putting (12) in (11), it yields,

$$\dot{V}(t, x_t) \leq x^T f_2(x) + \frac{|g|}{2} \left[3 + \frac{1}{1 - \tau} \right] x^T x + \frac{|g|}{2} \left[1 - \frac{1-h}{1 - \tau} \right] x_t(-h)^T x_t(-h). \quad (13)$$

The third term of the right hand in (13) is negative definite because $\dot{h} < \tau < 1$. By applying *Lemma 1* to (13)

and organizing terms, it yields,

$$\dot{V}(t, x_t) \leq -\lambda x^T x + |g| \left[\frac{2 - \frac{3}{2}\tau}{1 - \tau} \right] x^T x. \quad (14)$$

From (14), condition (3) –*Fact 1*– is satisfied if,

$$-\lambda + |g| \left[\frac{2 - \frac{3}{2}\tau}{1 - \tau} \right] < 0. \quad (15)$$

Inequalities (10) and (14) verify the stability conditions given by *Fact 1* –inequalities (2) and (3)–. Then, the proposed *Theorem 1* is proven ensuring the asymptotic stability of the system (4). Δ

Figure 1 shows the effect of the maximum derivative of the time delay on the stability region –given by (15)– for three arbitrary values $|g|=0.5$, $|g|=1$ and $|g|=2$.

The achieved stability condition is independent of the delay amplitude and it depends on three main factors: the exponential rate λ of the non-delayed system $\dot{x} = f_2(x)$, the norm $|g|$ of the delayed non-linear function $g(x, x(t-h))$ and the maximum time-derivative τ of the time delay. Moreover, the greater the temporal derivative of the time delay (τ), the stronger the stability of the non-delayed system (higher λ) to reach the stability of the system with time delay. In addition, if $|g| \rightarrow 0$ then the proposed stability condition tends to the stability condition of a non-delayed system, this is: $\lambda < 0$.

IV. STATEMENT OF THE CONTROL PROBLEM

This section describes the analysed control problem on a bilateral teleoperation system of mobile robots. Figure 2 shows a general diagram of a teleoperation system.

The human operator drives a mobile robot through a hand-controller generating velocity commands to send to the remote site, which will be executed by the mobile robot. The mobile robot and obstacles position is visually back-fed to the human operator. We suppose that the obstacles position generates a fictitious force, which depends on the distance between the mobile robot and the obstacle.

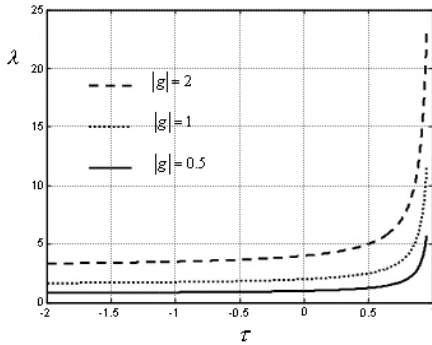

Fig. 1. Stability region in function of τ .

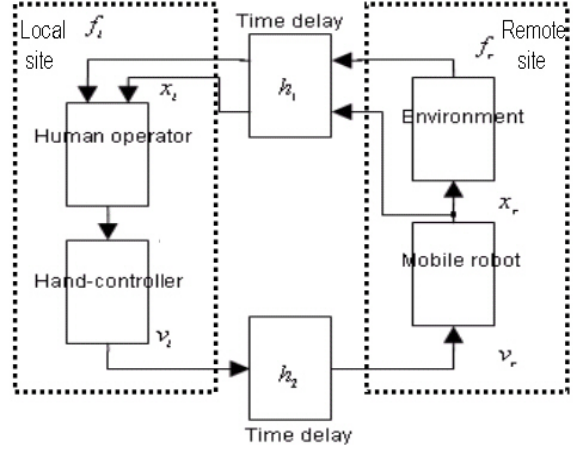

Fig.2. General block diagram of a teleoperation system of a mobile robot.

The main signals of the system are the position x_r and force f_r on the remote site, the received position x_l and force f_l on the local site, the velocity command v_l generated in the local site and the velocity reference v_r applied to the mobile robot. On the other hand, the communication channel is represented by a time delay h composed by a forward delay h_2 (from the local site to the remote site) and a backward delay h_1 (from the remote site to the local site), i.e.,

$$h(t) = h_1(t) + h_2(t). \quad (16)$$

We will consider the mobile robot as a unicycle located at a non-zero distance from the objective frame $\langle g \rangle$. In addition, attached to the robot there exists the frame $\langle a \rangle$, as shown in Fig. 3.

We consider the vehicle position in Polar Coordinates, where the state variables are the polar coordinates ρ, α, θ measured between the frame $\langle g \rangle$ and the frame $\langle a \rangle$. The kinematic equations can be written as,

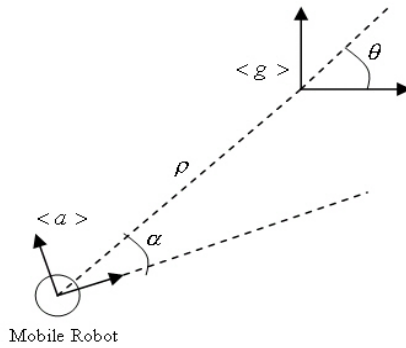

Fig.3. Position and orientation of a mobile robot.

$$\begin{cases} \dot{\rho} = -v_{rv} \cos \alpha \\ \dot{\alpha} = -v_{r\omega} + v_{rv} \frac{\sin \alpha}{\rho} \\ \dot{\theta} = v_{rv} \frac{\sin \alpha}{\rho} \end{cases} \quad (17)$$

Where $v_{rv}, v_{r\omega}$ are the linear and angular velocities of the mobile robot.

The objective of the teleoperation system is that a human operator (placed on the local site) drives a mobile robot (placed on the remote site) to reach the frame $\langle g \rangle$ in spite of the time varying delay, this is, that the distance error (state) $-\text{in this case, without final orientation-} x := [\rho, \alpha] \rightarrow 0$ as $t \rightarrow \infty$ starting from any non-zero distance from $\langle g \rangle$.

V. MODEL OF MOTION CONTROL OF THE HUMAN OPERATOR

This section presents a model for the motion control of the human operator, which will be used later (Section VI) by the proposed delay compensation.

A. Human operator’s model for position control

The kinematic model proposed for the position controller of the human operator, which generates velocity commands $v_t = [v_{tv}, v_{t\omega}]$, is the following (Slawiński *et. al.*, 2005):

$$\begin{cases} v_{tv} = k_v \rho \cos \alpha \\ v_{t\omega} = k_\omega \alpha + k_v \sin \alpha \cos \alpha \end{cases} \quad (18)$$

where $k_v, k_\omega > 0$. Introducing the human controller (18) into the kinematic equations of the mobile robot (17), we obtain the following closed loop equations for the state $x := [\rho, \alpha]$:

$$\begin{cases} \dot{\rho} = -k_v \rho \cos^2 \alpha \\ \dot{\alpha} = -k_\omega \alpha \end{cases} \quad (19)$$

Lemma 2. The non-delayed teleoperation system (given by (19)) of a mobile robot (17) driven by a human controller represented by (18) is exponentially stable with rate $\lambda = \min\{k_v, k_\omega\}$.

Proof. The proposed Lyapunov candidate function is,

$$V(\rho, \alpha) = \frac{1}{2} \rho^2 + \frac{1}{2} \alpha^2. \quad (20)$$

The time derivative of $V(\rho, \alpha)$ along the trajectories of the system (19) is,

$$\dot{V} = -k_v \rho^2 \cos^2 \alpha - k_\omega \alpha^2. \quad (21)$$

Remark 1: The time-derivative of the functional $V(\rho, \alpha)$ is negative definite (21), then the trivial solution is globally asymptotically stable.

Remark 2: From (19), the solution for α is $\alpha(t) = \alpha(0)e^{-k_\omega t}$. The initial condition has a range given by $|\alpha(0)| \leq \pi$.

The problem to establish an exponential response on ρ is resolved by steps:

a) If the initial condition is $|\alpha(0)| \leq d\pi$, where d is a positive arbitrary constant lower than 0.5 -, then (21) can be expressed as,

$$\dot{V} < -k_v \rho^2 - k_\omega \alpha^2, \quad (22)$$

where $k_v' = k_v \cos^2(d\pi) > 0$. From (20) and (22) is simple to deduce that the non-delay system is exponentially locally stable with exponential rate $k_m = \min\{k_v', k_\omega\}$.

b) If the initial condition is $|\alpha(0)| > d\pi$, then there exists a finite time T_m defined by $T_m = -\frac{1}{k_\omega} \ln\left(\frac{d\pi}{\pi}\right)$ (from

Remark 2) which assures that $\alpha(T_m) \leq d\pi$.

c) We propose that the response of ρ is bounded by,

$$\rho(t) \leq \rho(0)e^{k_m T_m} e^{-k_m t}. \quad (23)$$

d) If $t \leq T_m$, from (23) and considering that the system is globally asymptotically stable – *Remark 1*-, it yields,

$$\rho(t) \leq \rho(0) \leq \rho(0)e^{k_m T_m} e^{-k_m t}.$$

e) If $t > T_m$, then $\alpha(t) < d\pi$ -from (b)-. Then, from (a) the response of ρ is bounded by the exponential response given by (23).

Remark 3: From steps (a), (b), (c), (d), (e) and *Remark 2*, the equilibrium point $x = [\rho \ \alpha]^T = 0$ is exponentially stable with rate $\lambda = k_m$. We choose d near zero, such that $k_v' \approx k_v > 0$, then $\lambda = k_m = \min\{k_v, k_\omega\}$. Δ

B. Fictitious force

The mechanical impedance regulation needs the feedback from the interaction force between the robot and its environment. The interaction forces imply physical contacts with the environment which, in the case of mobile robots, means a collision. To avoid obstacles, however, it’s necessary to interact with the environment without causing any collision. In such case, the interaction force is represented by a fictitious force, which depends on the distance between the robot and the obstacle, as shown the Fig. 4.

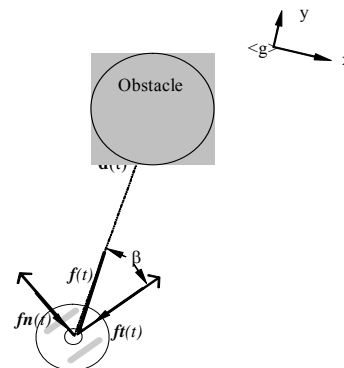

Fig. 4. Impedance control with fictitious force.

The magnitude of the fictitious force f is computed as $f(t) = a - bd(t)$, where a, b are positive constants such that $a - bd_m = 0$, d_m is the robot-obstacle maximum distance, and $d(t)$ is the robot-obstacle distance ($0 \leq d(t) \leq d_m$), which is measured through ultrasonic or type-camera sensors. On the other hand, the angle of the fictitious force is β (see Fig. 4). The fictitious force on the remote site is $f_r := [f_t \ f_n]^T$ (see Fig. 2).

C. Reactive control mode with decision of the human operator

The impedance model of the human operator is defined by $Z = Bs + K$, where B, K are positive constants; while the reference error is defined by $\tilde{x} = Z^{-1}f_r$, where $f_t = f \cos \beta$ is the component of f on the robot motion direction. The reference error \tilde{x} is transformed to a rotation angle $\psi = \tilde{x}D(t)$ applied on the position reference (Mut *et. al.*, 2002); where $f_n = f \sin \beta$ is the component of f normal to the robot's motion direction and $D(t)$ represents the human operator's decision. If the environment and the task are perfectly known, then the decision could be predicted. We assume that the task and environment are according to $D = \text{sign}(f_n)$. When the fictitious force is zero, the reference error is zero too, and then the objective of the motion control is achieved.

D. Reactive control mode of the human operator

When the environment or the task are not known, then the fictitious force modifies the distance error ρ and the angular error α as: $[\rho \ \alpha]^T = [\rho \ \alpha]^T - K^{-1}[f_t \ f_n]^T$, where f_t is the component of f on the robot motion direction, f_n is the component of f normal to the robot's motion direction, and the impedance model of the human operator is defined by $K^{-1} = \text{diag}[K_\rho \ K_\alpha] \in \mathbb{R}^{2 \times 2}$, where $K_\rho, K_\alpha > 0$ represent the human operator's elasticity in response to fictitious force generated by the distance robot-obstacle.

E. Experimental validation of the human operator's model to drive the mobile robot

Figure 5 shows the executed trajectories by the mobile robot driven by a human operator in two different experiences and also the trajectory using an automatic control, it is composed by both the position controller described in sub-section A, and the impedance controller described in sub-section C. We conclude that the proposed model of the human operator is satisfactory. The impedance loop (the desired impedance is represented by a stable and proper strictly linear filter) only modifies the reference of the motion control. However, it won't be considered later to simplify the stability analysis of the bilateral teleoperation system (Section VI).

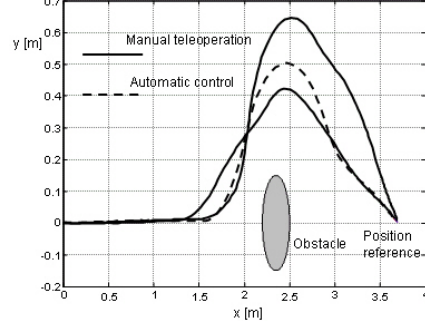

Fig. 5. Trajectories of the mobile robot using manual teleoperation and automatic control.

VI. CONTROL STRUCTURE FOR BILATERAL TELEOPERATION OF MOBILE ROBOTS

This section describes the proposed control structure applied to a bilateral teleoperation system of mobile robots.

The proposed delay compensation does not modify the feedback position from the remote site. In addition, the local site sends a signal $v_r(t) - \Delta v(t - h_1)$ to the remote site; this signal combines the velocity command generated by the human operator in a time instant and the received position information (which stimulates the operator) in such moment. In the remote site, the proposed delay compensation uses the current position of the mobile robot to modify the signal $v_r(t - h_2) - \Delta v(t - (h_1 + h_2))$ and to establish the velocity reference $v_r(t)$. Figure 6 shows a block diagram of the delayed bilateral system introducing the proposed time-delay compensation.

The delay compensation is placed on both the local and remote sites and it is defined by an approximated model of the local site (Section V) as follows,

$$\begin{cases} \Delta v_v = k_{v_c} \rho \cos \alpha \\ \Delta v_\omega = k_{\omega_c} \alpha + k_{v_c} \sin \alpha \cos \alpha \end{cases} \quad (24)$$

where k_{v_c}, k_{ω_c} are the parameters of the delay compensation and the vector $\Delta v = [\Delta v_v, \Delta v_\omega]^T$ is the output of the proposed delay compensation.

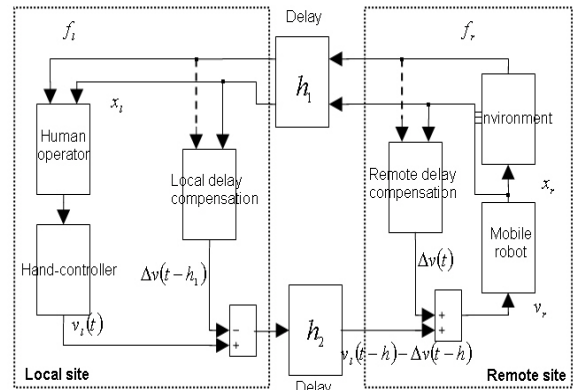

Fig. 6. Block diagram of the teleoperation system with delay compensation.

Now, we analyze the system stability using the proposed delay compensation and also considering that the local site is represented by a time-invariant kinematic model. We computed the vector $v_r = [v_{rv}, v_{ro}]$ (Fig. 6), which is applied on the mobile robot (17) as follows,

$$\begin{cases} v_{rv} = v_{rv}(t - (h_1 + h_2)) - \Delta v_{rv}(t - (h_1 + h_2)) + \Delta v_{rv}(t) \\ v_{ro} = [v_{ro}(t - (h_1 + h_2)) - \Delta v_{ro}(t - (h_1 + h_2)) + \Delta v_{ro}(t)] \end{cases} \quad (25)$$

From (17), the evolution of the state $x := [\rho, \alpha]$ of the delayed system is given by,

$$\begin{cases} \dot{\rho} = -v_{rv} \cos \alpha \\ \dot{\alpha} = -v_{ro} + v_{rv} \frac{\sin \alpha}{\rho} \end{cases} \quad (26)$$

We put (16), (18) and (24) in (25) to obtain a intermediate equation which is incorporated in (26) describing the delayed system as follows:

$$\begin{cases} \begin{bmatrix} \dot{\rho}(t) \\ \dot{\alpha}(t) \end{bmatrix} = f_2(\rho(t), \alpha(t)) + g(\rho(t), \alpha(t), \rho(t-h), \alpha(t-h)) \\ f_2(.) = \begin{bmatrix} -k_{vc} \rho \cos^2 \alpha \\ -k_{\omega c} \alpha \end{bmatrix} \\ g(.) = \begin{bmatrix} -\tilde{k}_v \rho(t-h) \cos \alpha(t-h) \cos \alpha \\ -\tilde{k}_{\omega} \alpha(t-h) + \tilde{k}_v \rho(t-h) \cos \alpha(t-h) N \end{bmatrix} \end{cases} \quad (27)$$

where $\tilde{k}_v = k_v - k_{vc}$, $\tilde{k}_{\omega} = k_{\omega} - k_{\omega c}$ and $N = \frac{\sin \alpha}{\rho} - \frac{\sin \alpha(t-h)}{\rho(t-h)}$.

If the delay compensation is an exact model of the local site, then $[\tilde{k}_v, \tilde{k}_{\omega}] \rightarrow 0$ and therefore $|g| \rightarrow 0$ in (27). Then, from (19) and (27) the system will represent the non-delayed real system and from Lemma 2, the delayed system will be asymptotically stable.

On the other hand, if $[\tilde{k}_v, \tilde{k}_{\omega}] \neq 0 \Rightarrow |g| \neq 0$. To simplify this analysis, we suppose that $\tilde{k}_v = 0$, then from (27), the incremental gain is,

$$|g| = |\tilde{k}_{\omega}| \quad (28)$$

From Theorem 1 (given by (8)), Lemma 2 and (28), the stability condition is expressed as,

$$-\lambda + |\tilde{k}_{\omega}| \left[\frac{2 - \frac{3}{2}\tau}{1 - \tau} \right] < 0 \quad (29)$$

The proposed control structure allows us to separate the delayed system into the non-delay real system (f_2 in (27)) and a new delayed subsystem (delayed function g in (27)). In the general case ($|g| \neq 0$), the proposed control strategy allows ensuring the system stability through a condition imposed on the non-delayed system (29) that depends on the maximum derivative τ of the delay and the gain $|g|$ of the delayed non-linearity of the system.

VII. EXPERIMENTAL RESULTS

To illustrate the performance and stability of the proposed control structure for mobile robot teleoperation, experiments have been conducted on a

Pioneer 2DX mobile robot through a simulated and real communication channel. The human operator receives visual feedback of position from a Logitech webcam placed on the remote site. The objective of control is to achieve the position reference avoiding a type cylinder or cube obstacle placed on the workspace of the remote site. It should be noticed that the impedance control loop is active when the mobile robot detects an obstacle at a distance less than 1.5[m] using ultrasonic sensors.

A. Teleoperation with simulated delay

The hand-controller used in this experiment is a Logitech Wingman joystick. The initial condition is $\rho(\theta) = 3.7[m]$, $\alpha(\theta) = 0[rad]$ for $\theta \in [-h(t_0), 0]$. The time delay is simulated by software. The used parameters for the delay compensation are: $B = 1[N/rad]$, $K = 3[N.s/rad]$ for the force compensation (sub-section C in section V) and $k_{vc} = 0.4[m/s]$, $k_{\omega c} = 0.25\pi[rad/s]$ for the position compensation (compensation of position and force in presence of time delay).

Figure 7 shows the executed trajectories by the Pioneer 2DX mobile robot for diverse delays. The advantage of using the delay compensation is clear.

Figure 8 shows the evolution of the state norm $|x| = [\rho, \alpha]$ of the delayed teleoperation system for various delays. On the other hand, the Fig. 9 shows the evolution of the linear velocity of the mobile robot. The maximum linear velocity varies between 0.4 and 0.5 $\left[\frac{m}{sec.} \right]$ for the diverse experiments.

The response of the delayed teleoperation system using the delay compensation is similar to the manual teleoperation without time delay (reference response); therefore the performance of the system is good.

B. Teleoperation through Internet between Brazil and Argentina

Now, the performance of the proposed control structure for bilateral teleoperation of a mobile robot (Pioneer 2DX) driven by a human operator through Internet between San Juan (Argentina) and Vitoria (Espírito Santo, Brazil) is presented. The hand-controller used is

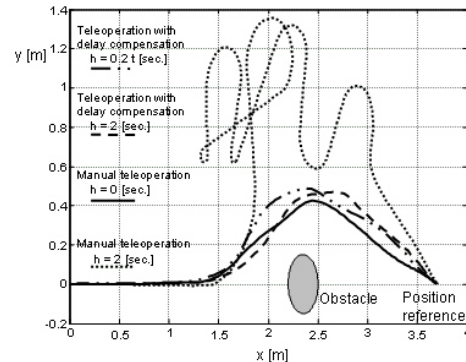

Fig. 7. Trajectories of the mobile robot using the delay compensation for various delays.

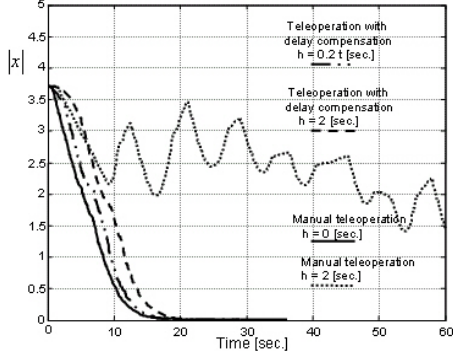
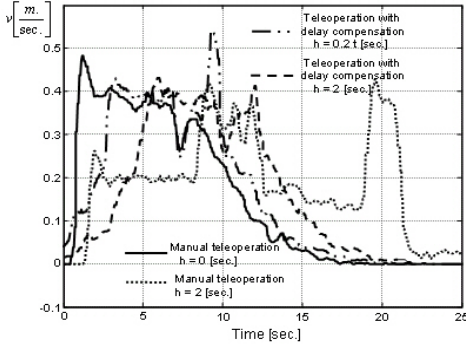

 Fig. 8. Evolution of the norm of the state x .

Fig.9. Linear velocity of the mobile robot.

a commercial steering wheel with accelerator pedal. An obstacle type-cube is placed on the workspace of the remote site.

The used parameters for the delay compensation are: $K_p = 3[m/N]$, $K_v = 1[rad/N]$ for the force compensation (subsection D in section V) and $k_{vc} = 0.4[m/s]$, $k_{\omega c} = 0.25\pi[rad/s]$ for the position compensation (compensation of position and force in presence of time delay).

Figure 10 shows the evolution of the time delay h and \dot{h} (which is estimated using a differentiator filter). Figure 11 shows the trajectory of the mobile robot for this experiment. The human operator drives the mobile robot to reach the objective position avoiding the obstacle placed in the remote site.

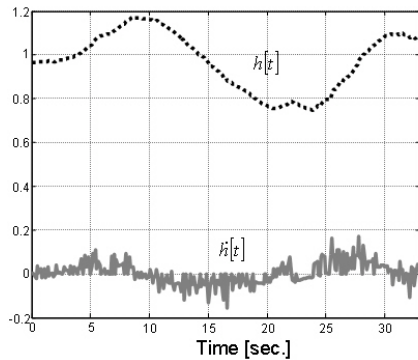

Fig. 10. Time-varying delay for the experiment B using Internet to link the local and remote sites.

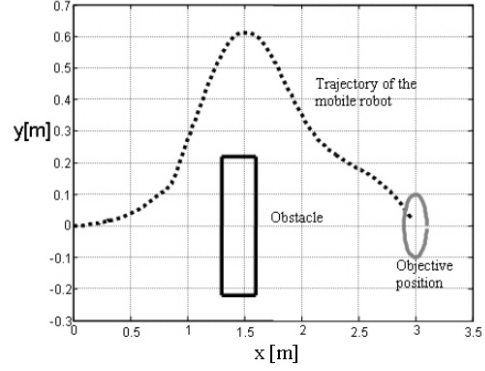
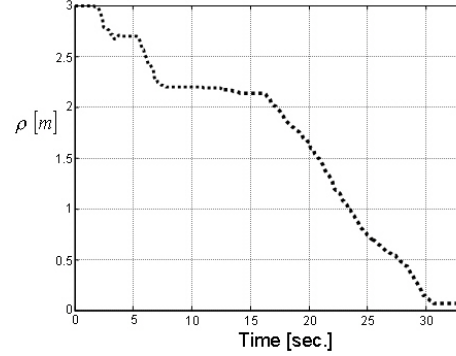

Fig. 11. Trajectory of the mobile robot teleoperated by a human operator through Internet.

 Fig. 12. Temporal evolution of the distance error ρ .

On the other, Fig. 12 shows the temporal evolution of the distance error ρ , it tends to zero as $t \rightarrow \infty$.

The response of the teleoperation system is satisfactory in spite of the time varying delay added by Internet.

C. Stability

Now, we analyse the stability of the teleoperation system. The maximum time-derivative of the time delay added by the simulated and real (Fig. 10) communication channel is approximately $\tau = 0.2$. On the other hand, the exponential rate of the non-delayed system is $\lambda = \min\{k_v, k_{\omega}\} = 0.4$ (see Lemma 2). From (29), we can express the stability condition on \tilde{k}_{ω} as,

$$-0.4 + |\tilde{k}_{\omega}| \left[\frac{2 - \frac{3}{2}(0.2)}{1 - (0.2)} \right] < 0 \rightarrow |\tilde{k}_{\omega}| < 0.1882 . \quad (30)$$

From (30) and the value of k_{ω} , we can conclude that the model used by the delay compensation could have parametric errors to a percentage of 20% .

VIII. CONCLUSIONS

In this paper it has been proposed a stable control structure for bilateral teleoperation systems of mobile robots. The proposed strategy includes a delay compensation placed on the local and remote sites of the teleoperation system and it uses a model of the local site.

Several experiments have shown a stable response

with good performance and transparency. In addition, a mobile robot was driven by a human operator with visual feedback through a simulated and real communication channel in a continuous way. From these results, we may conclude that the application of the proposed control structure on an industrial or commercial system is feasible.

The future work will be incorporating the dynamic model of the human operator on the proposed control structure. In addition, the parameters of the human operator will be identified to improve the performance of the teleoperation system.

REFERENCES

- Anderson, R.J. and M. Spong. "Bilateral control of Teleoperators with time delay", *IEEE Transaction and Automatic Control*, **34**, 494-501 (1989).
- Arcara, P. and C. Melchiorri. "Control schemes for teloperation with time delay: A comparative study", *Robotics and Autonomous Systems*, **38**, 49-64 (2002).
- Chopra N. and M. Spong. "Bilateral Teleoperation over the Internet: the Time Varying Delay Problem", *Proceedings of the American Control Conference*, Denver, Colorado, June 4-6, 155-160 (2003).
- Elhaji, I , N. Xi, W. Fung and Y. Liu, "Supermedia-Enhanced Internet-Based Telerobotics", *Proceedings of the IEEE*, **91**, 396-421 (2003).
- Fiorini, P. and R. Oboe, "Internet-Based Telerobotics: Problems and Approaches", *ICAR'97*, Monterey, CA, July 7-9, 765-770 (1997).
- Hale, J.K., *Theory of Functional Differential Equations*, Springer Verlag, New York (1977).
- Kolmanovskii, V.B. and A. Myshkis. *Introduction to the theory and applications of functional differential equations*. Dordrecht: Kluwer Academy (1999).
- Krasovskii, N.N., *Stability of Motion*, Stanford University Press (1963).
- Lawrence, .A., "Stability and Transparency in Bilateral Teleoperation", *IEEE Transactions on Robotics and Automation*, **9**, 624-637 (1993).
- Mut, V., J. Postigo, E. Slawiński and B. Kuchen. "Bilateral teleoperation of mobile robots", *Robotica*, Cambridge University Press, **20**, 213-221 (2002).
- Niemeyer, G. and J.J.E. Slotine. "Stable Adaptive Teleoperation", *IEEE Journal of Oceanic Engineering*, **16**, 152-162 (1991).
- Oboe, R. and P. Fiorini. "A Design and Control Environment for Internet-Based Telerobotics", *The International Journal of Robotics Research*, **17**, 433-449 (1998).
- Oboe, R., "Force Reflecting Teleoperation Over the Internet: The JBIT Project", *Proceedings of the IEEE*, **91**, 449-462 (2003).
- Richard, J.P., "Time-delay systems: an overview of some recent advances and open problems", *Automatica*, **39**, 1667-1694 (2003).
- Sheridan, T.B., "Teleoperation, Telerobotics and Telepresence: A Progress report", *Control Eng. Practice*, **3**, 205-214 (1995).
- Slawiński E., V. Mut and J. Postigo, "Bilateral teleoperation of mobile robots with delay", *Proceeding of the IEEE International Conference on Mechatronics and Automation (ICMA 2005)*, Niagara Falls, Canada, July, 1672-1677 (2005).

Received: September 21, 2005.

Accepted for publication: March 3, 2006.

Recommended by Guest Editors C. De Angelo, J. Figueroa, G. García and J. Solsona.